

DESENHO TÉCNICO – MODELO MAGOITO

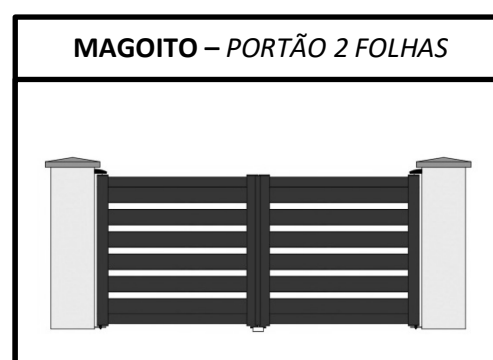

Notice de montage SABOT AUTOMATIQUE COMPOSITE

1 - Monter la butée sur le bras

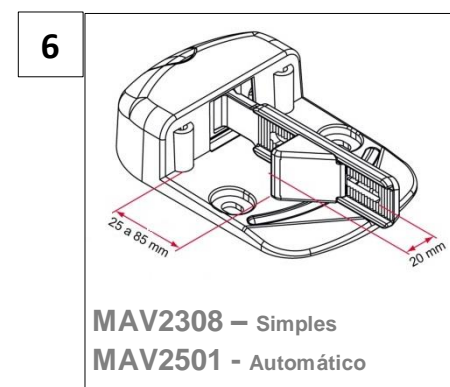
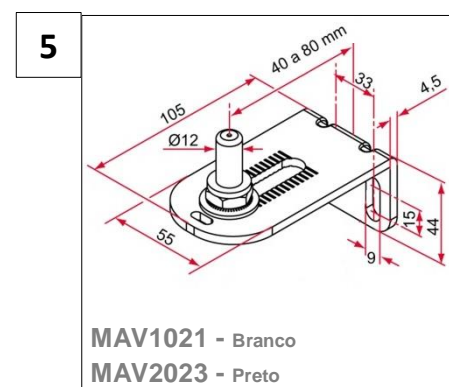
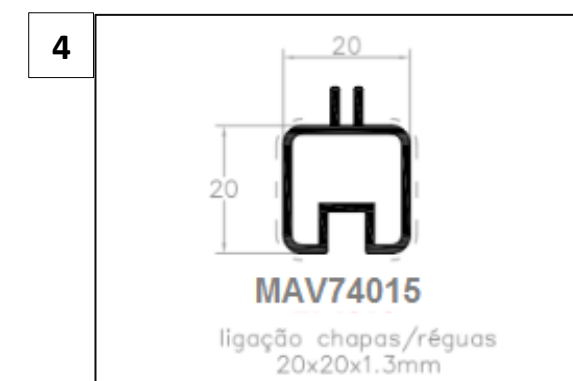
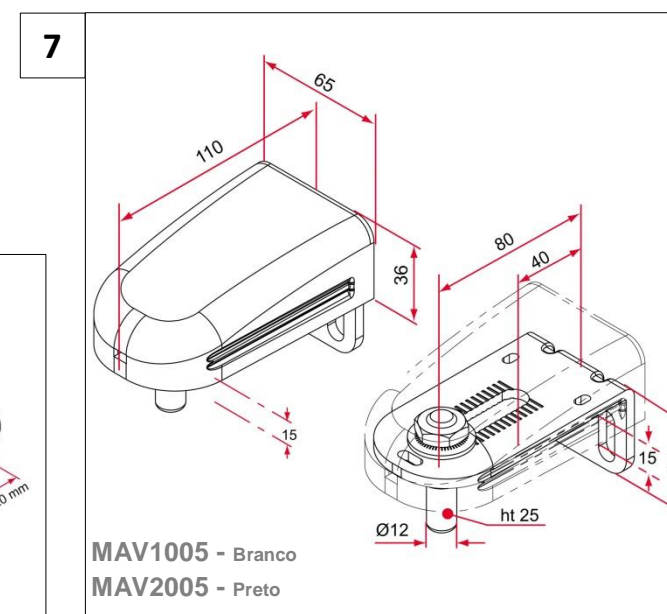
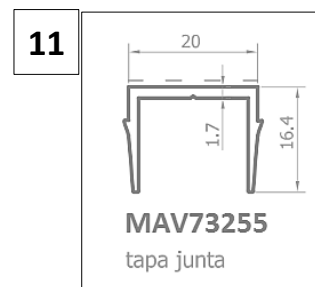
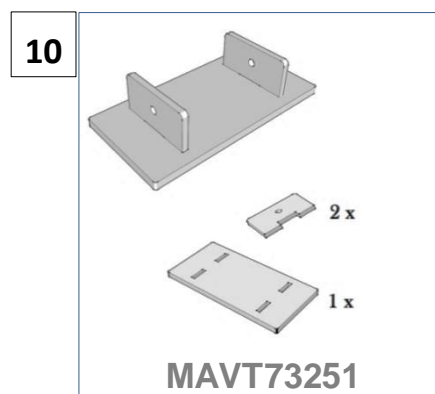
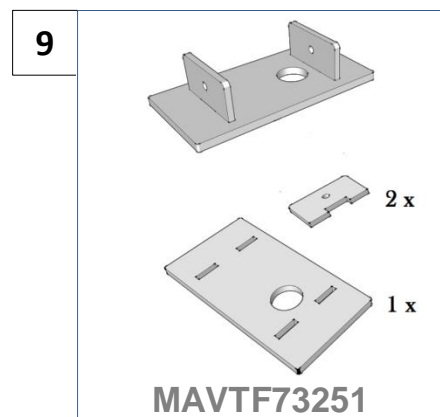
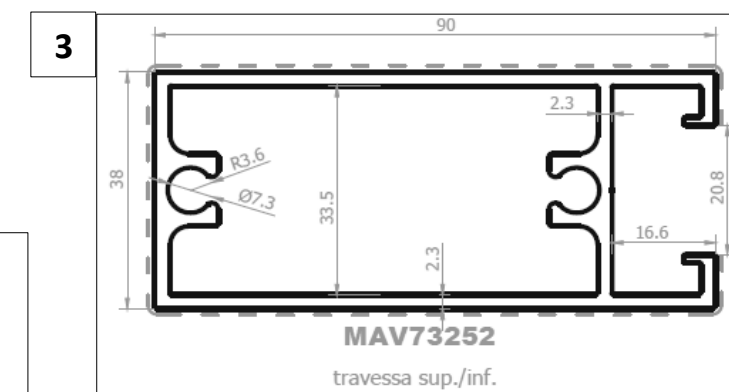
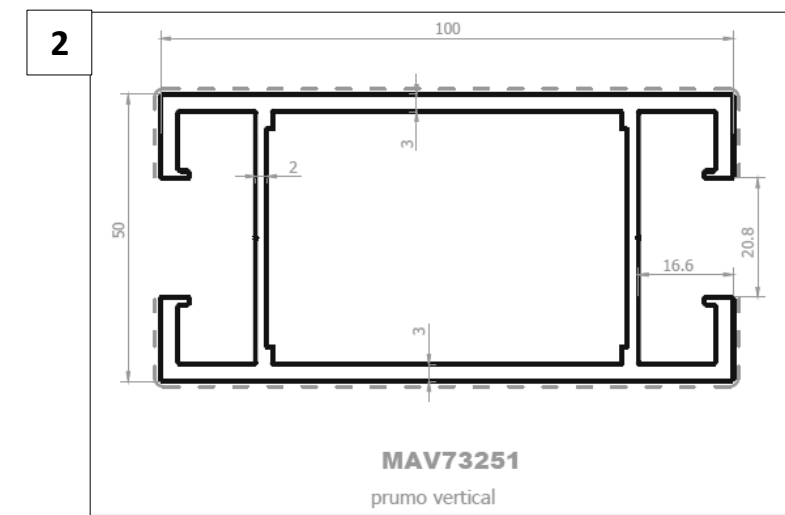
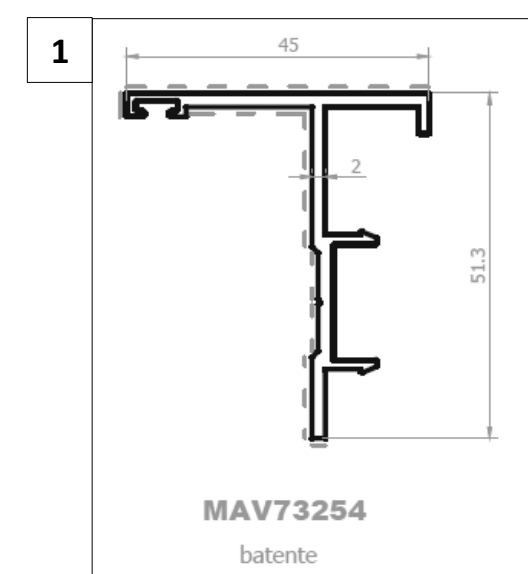
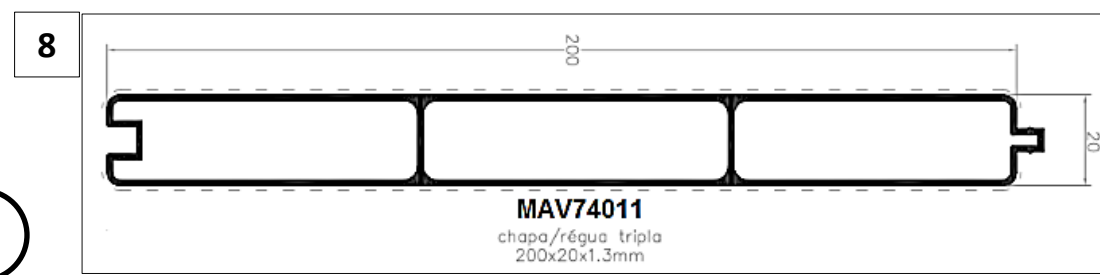
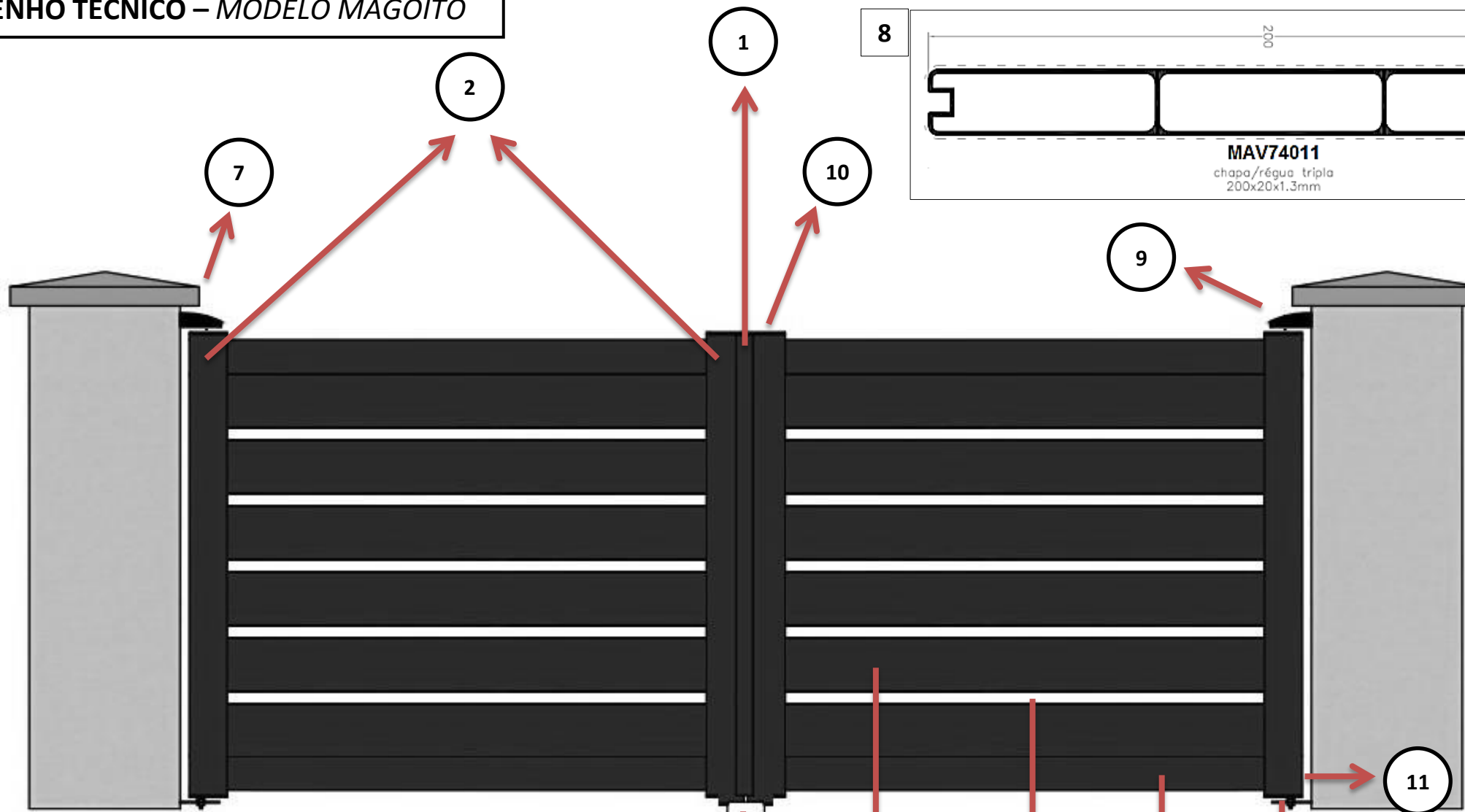
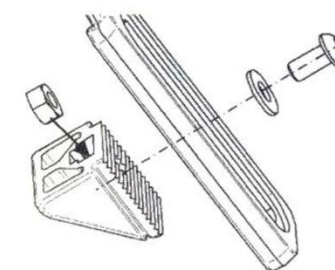

2 - Monter le sous-ensemble dans la semelle en fonction de la position du dormant

a) pour un dormant à droite

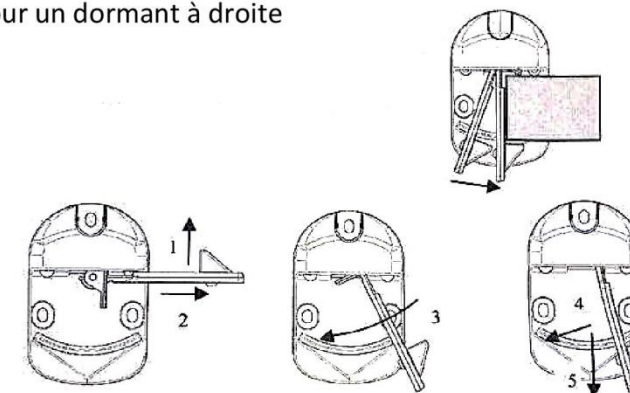

b) pour un dormant à gauche

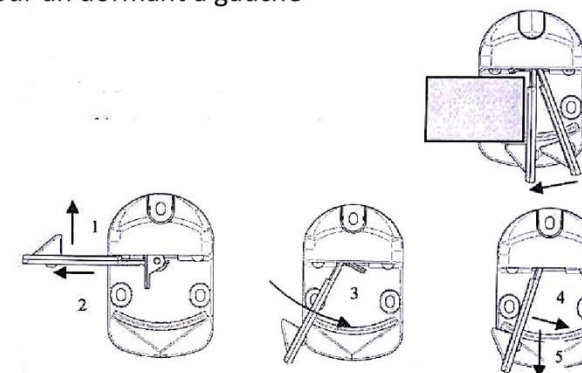

3 - Monter la cale de serrage et les amortisseurs

Cale de serrage

Amortisseurs

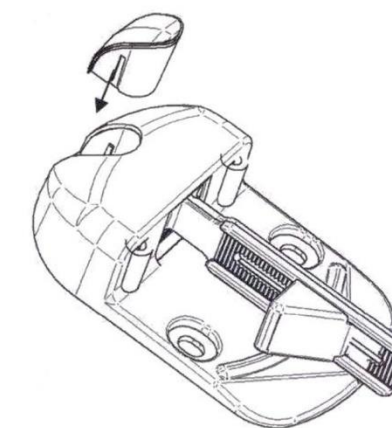
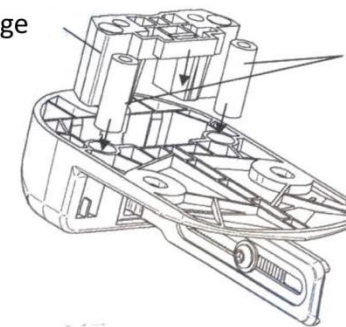

4 - Percer et fixer le sabot au sol, positionner le bouchon.
(Avec des fixations adaptées au support -Ø8 maxi).

Notice : « Gond platine en L, Carenage Bas H36 »

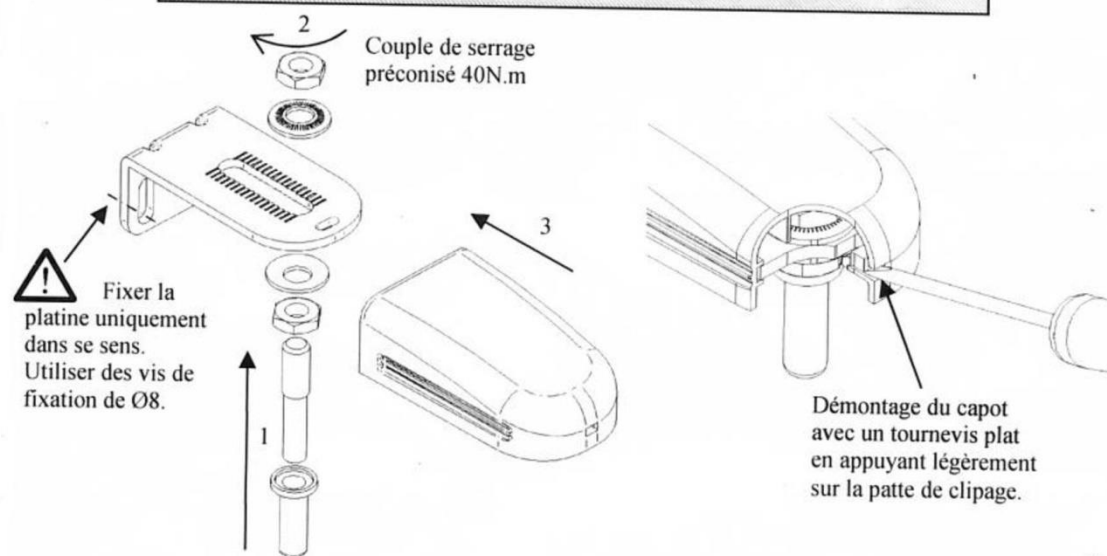

Notice de montage « GOND SUR PLATINE NON CARENE »

